

Selection - PR-AC 506 T

Product Code	7PA5065
Requested Air Volume	5 995 m ³ /h
Requested Pressure	116 Pa
Air Volume	5 997 m ³ /h
Static Pressure	116 Pa
Total Pressure	160 Pa
Velocity Pressure	43,9 Pa
Outlet Velocity	8,48 m/s
SFP	0,16 W/l/s
Fan Total Efficiency	100,7 %
Fan Static Efficiency	73,1 %
Fan Speed	1000 rpm
Air Properties	1,22kg/m ³ / 15°C/ 0m/ 50% RH
Motor Input Power	0,265 kW
Temperature Range	-15°C +70°C

Construction Settings

Arrangement	4
Discharge	LG-270
Motor Position	D

Motor selection

Electrical Supply	400/3/50
Motor Rating	0.55 kW
Enclosure/Class	55 / F
Poles number	6
Motor Speed	910 rpm
Full Load Current	1.65 A

ERP Information

ERP Compliance	Exempt
Type	-
Regulation	-
Category of measure	-

Fan Performance

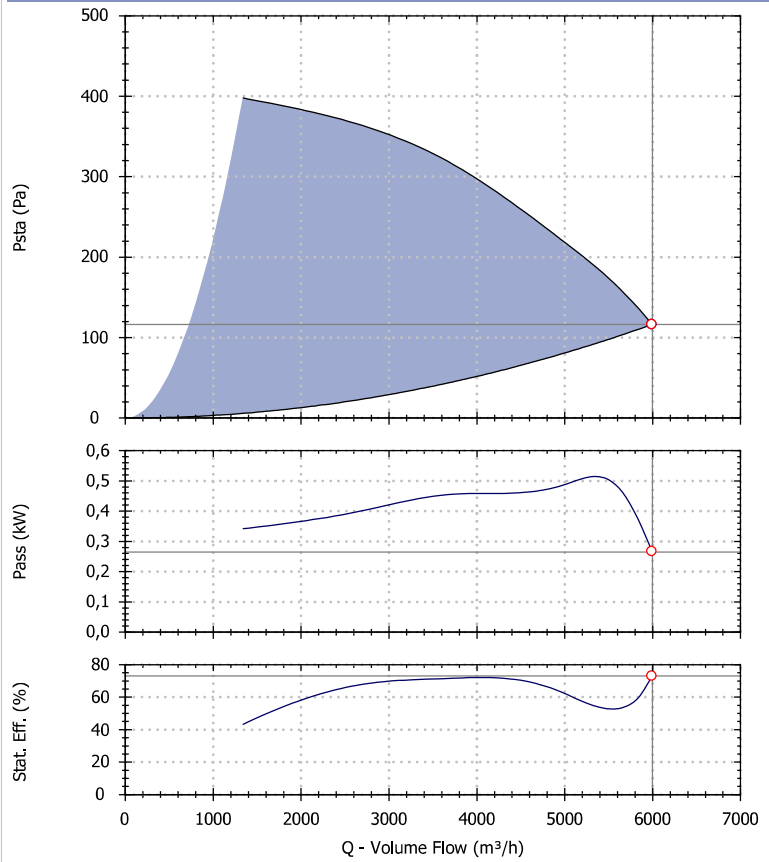

Sound Performance

Hz	63	125	250	500	1k	2k	4k	8k	Overall	
Lw	65	67	68	63	62	57	49	41	73	dB
Lw(A)	39	51	59	60	62	58	50	40	66	dB(A)
LpA @ 3m	18	30	39	39	41	38	29	19	46	dB(A)

Sounds spectra refers to Maico Italia measures performed in our laboratories according to 123. The values provided are just indicative of the situation and Maico Italia declines every responsibility in case different levels measured by our customers as the installation types and the environmental variables may increase/decrease these values.

Drawing and Dimensions - PR-AC 506 T

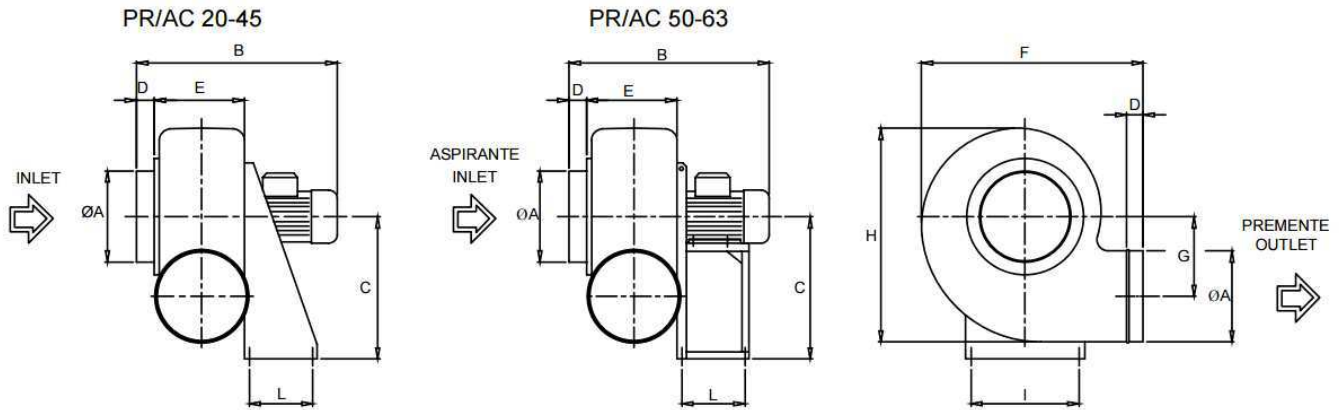

Key	B	C	D	E	F	G	H	I	kg	L	M	N	O	OA
Value [mm]	655	630	50	355	796	360	956	289	115	197	150	-	170	400

Drawings are indicative of the size of the selected fan. These dimensions may vary, even without any explicit advice. To have more accurate information contact your local agency.

Electric Wire Connections

