

Selection - FC 354 T

Product Code	1FC3648
Requested Air Volume	3 295 m ³ /h
Requested Pressure	10,4 Pa
Air Volume	3 300 m ³ /h
Static Pressure	10,5 Pa
Total Pressure	66 Pa
Velocity Pressure	55 Pa
Outlet Velocity	9,53 m/s
SFP	0,26 W/l/s
Fan Total Efficiency	25,1%
Fan Static Efficiency	4 %
Air Properties	1,22kg/m ³ / 15°C/ 0m/ 50% RH
Motor Input Power	0,241 kW
Temperature Range	+100°C
Fan Energy Index (FEI)	2,59

Motor Selection

Electrical Supply	400/3/50
Motor Rating	0.25 kW
Enclosure/Class	55 / F
Frame Size	71
Poles number	4
Motor Speed	1440 rpm
Full Load Current	0.86 A

ERP Information

ERP Compliance	Exempt
Type	
Regulation	-
Category of measure	-

Fan Performance

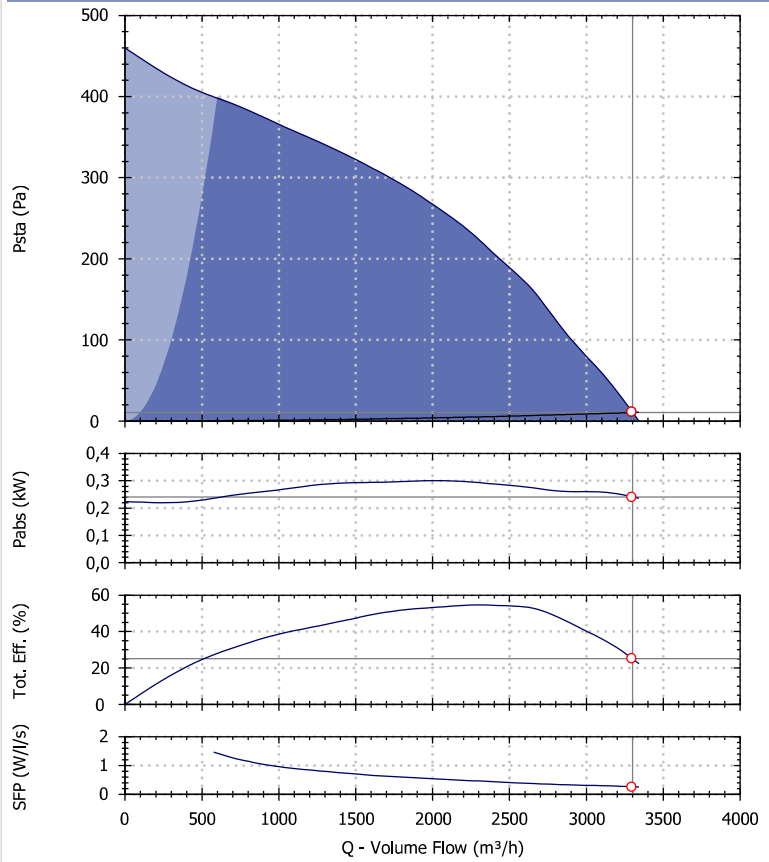

Performances refers to Maico Italia measures and may vary according to the installation type.

Sound Performance

Hz	63	125	250	500	1k	2k	4k	8k	Overall
Lw	74	78	77	76	73	69	64	55	83
Lw(A)	48	62	68	73	73	70	65	54	78
LpA @ 6m	21	35	41	46	46	43	38	27	51

Sounds spectra refers to Maico Italia measures performed in our laboratories. The values provided are just indicative of the situation and Maico Italia declines every responsibility in case different levels measured by our customers as the installation types and the environmental variables may increase/decrease these values.

Drawing and Dimensions - FC 354 T

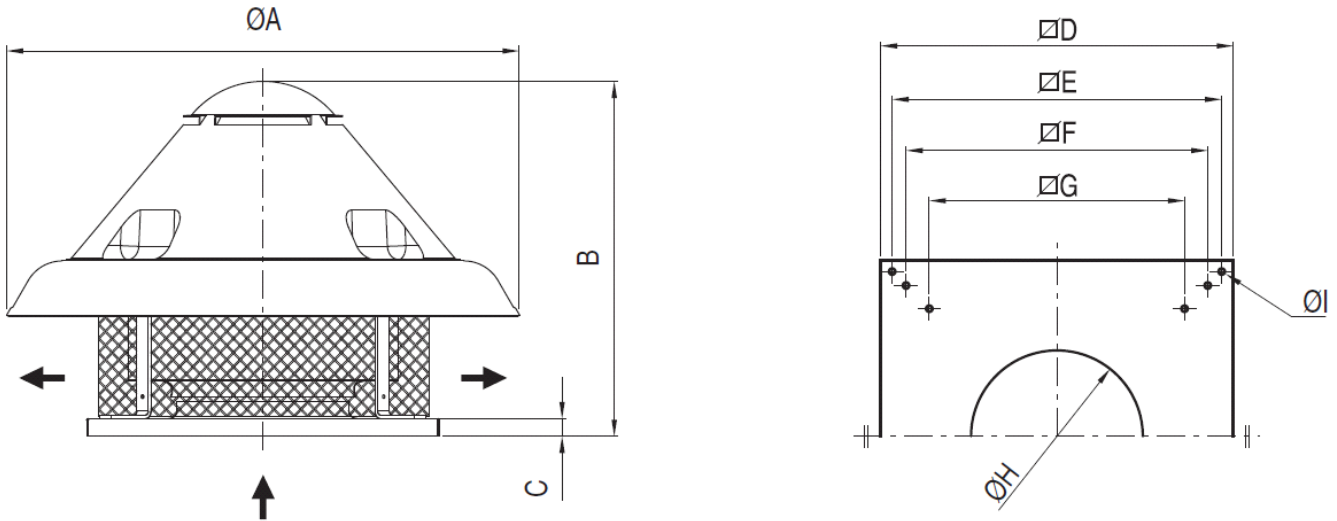

Key	ΦA	B	C	D	E	G	ΦH	ΦI	kg
Value [mm]	750	580	38	500	450	380	270	12	25

Drawings are indicative of the size of the selected fan. These dimensions may vary, even without any explicit advice. To have more accurate information contact your local agency.

Electric Wire Connections

