

AC centrifugal fan

Backward curved



- **Impeller material:** All-plastic impeller of PA 6.6 GV, injected round sheet-metal plate
- **Bearings:** Maintenance-free ball bearings
- **Direction of rotation:** Right, looking at rotor

Nominal data

Type	Motor	Voltage 1- VAC	Frequency Hz	Air flow m³/h	Speed 1/min	Power consumption W	Current draw A	Capacitor capacity uF/V	Sound pressure level dB(A)	Ambient temperature 50Hz °C	Weight kg
R2E133BH6605	M2E052BF	230	50	290	2800	24	0.11	1.0 / 400	56	-25 .. 45	0.7

Subject to modification

Characteristic: Pressure over air flow at 50Hz

n [1/min]	P ₁ [W]	I [A]	LpA [dBA]	ntL [%]
--------------	-----------------------	----------	--------------	------------

1 2710	25	--	--	--
2 2700	26	--	--	--

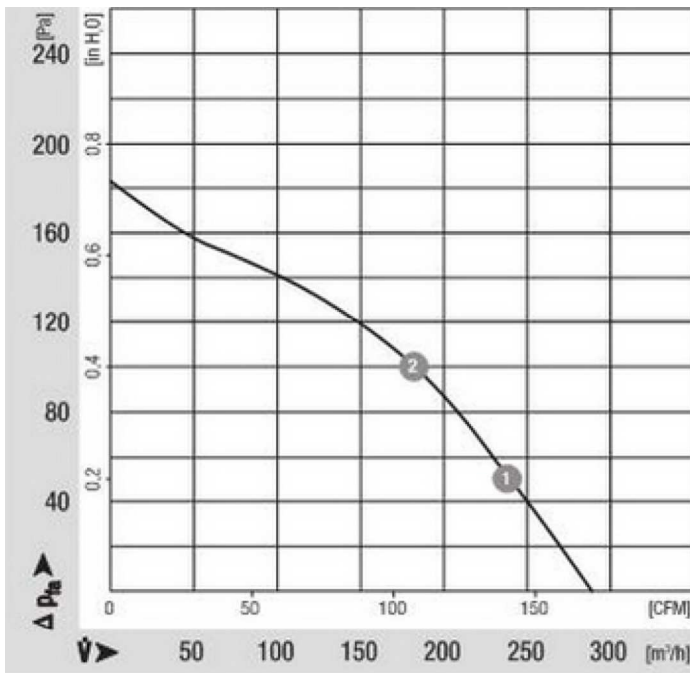

AC centrifugal fan

Backward curved

Specific drawing

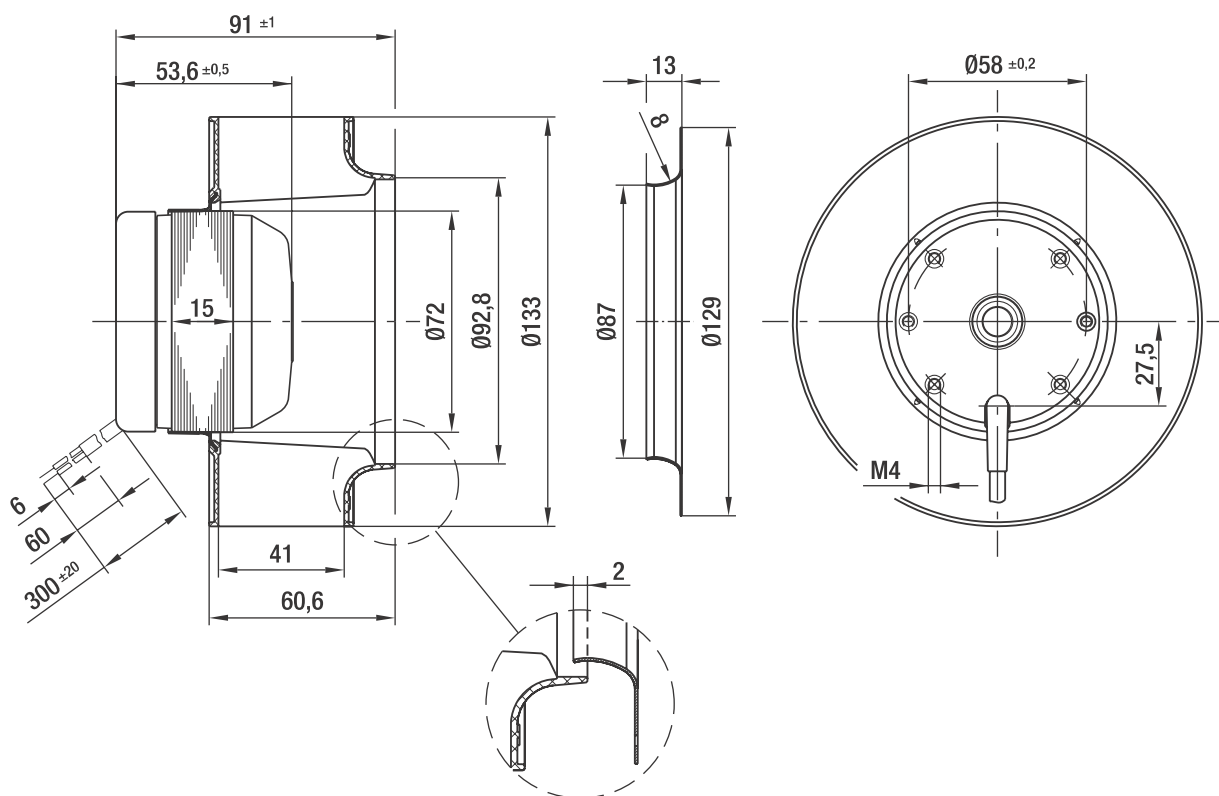

Connection illustration

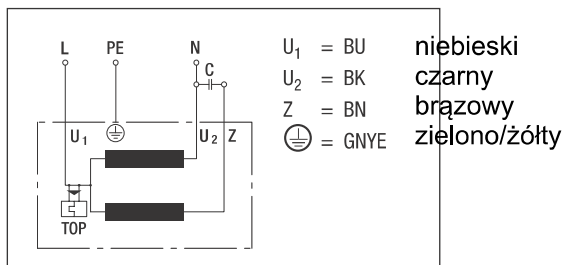

Technical description

- **Impeller material:** All-plastic impeller of PA 6.6 GV, injected round sheet-metal plate
- **Direction of rotation:** Right, looking at rotor
- **Cable layout:** Variable
- **Operating mode:** S1
- **Protection class:** I
- **Approvals:** CE
- **Bearings:** Maintenance-free ball bearings
- **Number of impeller blades:** 7
- **Screw depth:** Max. 5 mm
- **Insulation class:** "B"
- **System of protection:** IP 44

AC centrifugal fan

Backward curved

Contact

ebm-papst Mulfingen GmbH & Co. KG

Bachmühle 2

D-74673 Mulfingen

Phone +49 (0) 79 38 / 81-0

Fax +49 (0) 79 38 / 81-110

info1@de.ebmpapst.com

www.ebmpapst.com

MKP motor capacitor (without fuse), 1.0 μ F

Order No.	Capacity
02100-4-7320	1.0 μ F

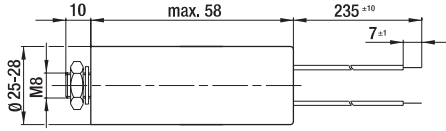

Technical description

- **Material:** Housing of Thermoplast
- **Connecting cable:** Multi-core PVC wire 0.5 mm² (16 x 0.2 mm²) with wire-end clamp
- **Approvals:** VDE in accordance with DIN EN 60252 (VDE 0560/8)
- **Expected service life:** 400 VDB; -25 to +85°C; 30,000 hrs.; Class A
450 VDB; -25 to +85°C; 10,000 hrs.; Class B

Contact

ebm-papst Mulfingen GmbH & Co. KG
Bachmühle 2
D-74673 Mulfingen
Phone +49 (0) 79 38 / 81-0
Fax +49 (0) 79 38 / 81-110
info1@de.ebmpapst.com
www.ebmpapst.com

Inlet nozzle

Order No.

09566-2-4013

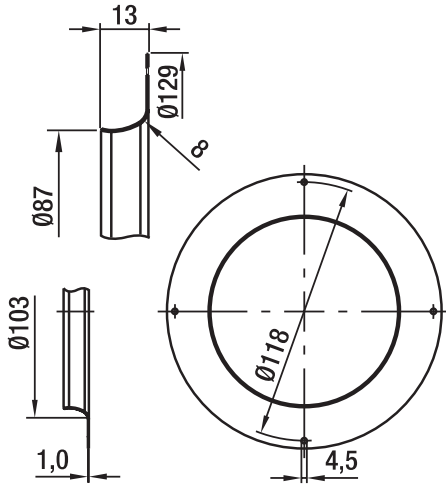

Technical description

- **Material:** Sendzimir galvanized sheet steel

Contact

ebm-papst Mulfingen GmbH & Co. KG

Bachmühle 2

D-74673 Mulfingen

Phone +49 (0) 79 38 / 81-0

Fax +49 (0) 79 38 / 81-110

info1@de.ebmpapst.com

www.ebmpapst.com